

FEATURES

- Glass Passivated Die Construction
- Fast Recovery Time For High Efficiency
- Low Forward Voltage Drop and High Current Capability
- Surge Overload Rating to 30A Peak
- Ideally Suited for Automated Assembly
- Plastic Material: UL Flammability Classification Rating 94V-0

Mechanical Data

- Case: Molded Plastic
- Terminals: Solder Plated Terminal - Solderable per MIL-STD-202, Method 208
- Polarity: Cathode Band or Cathode Notch
- SMA Weight: 0.064 grams (approx.)
- SMB Weight: 0.093 grams (approx.)
- Mounting Position: Any
- Marking: Type Number

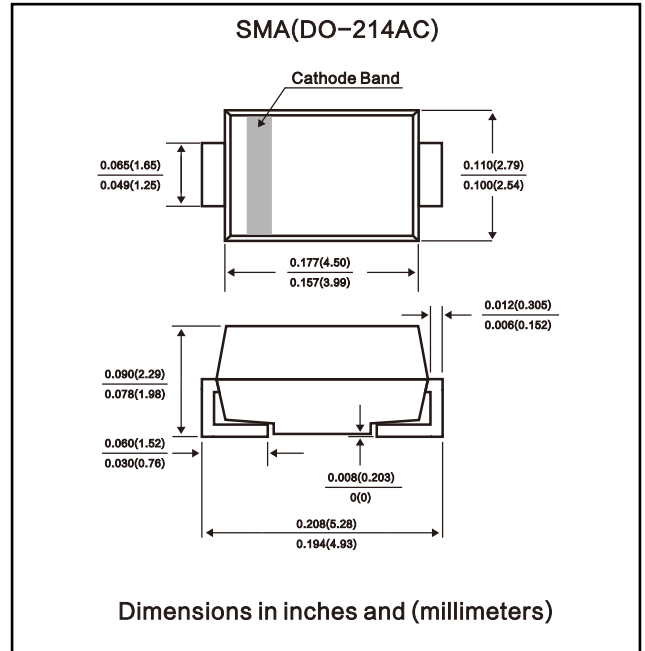

MAXIMUM RATINGS AND ELECTRICAL CHARACTERISTICS

Rating at 25 °C ambient temperature unless otherwise specified.
 Single phase, half wave, 60 Hz, resistive or inductive load.
 For capacitive load, derate current by 20%

Type Number	Symbol	RS 2A	RS 2B	RS 2D	RS 2G	RS 2J	RS 2K	RS 2M	Units
Maximum Recurrent Peak Reverse Voltage	V_{RRM}	50	100	200	400	600	800	1000	V
Maximum RMS Voltage	V_{RMS}	35	70	140	280	420	560	700	V
Maximum DC Blocking Voltage	V_{DC}	50	100	200	400	600	800	1000	V
Maximum Average Forward Rectified Current See Fig. 1 @ $T_L=100^\circ\text{C}$	$I_{(AV)}$	2.0							A
Peak Forward Surge Current, 8.3 ms Single Half Sine-wave Superimposed on Rated Load (JEDEC method)	I_{FSM}	50							A
Maximum Instantaneous Forward Voltage @ 2.0A	V_F	1.3							V
Maximum DC Reverse Current @ $T_A=25^\circ\text{C}$ at Rated DC Blocking Voltage @ $T_A=125^\circ\text{C}$	I_R	5 200							μA μA
Maximum Reverse Recovery Time (Note 1)	T_{rr}	150				250	500		nS
Typical Junction Capacitance (Note 2)	C_j	50							pF
Typical Thermal Resistance (Note 3)	$R_{\theta JA}$ $R_{\theta JL}$	55 18							$^\circ\text{C} / \text{W}$
Operating Temperature Range	T_J	-55 to +150							$^\circ\text{C}$
Storage Temperature Range	T_{STG}	-55 to +150							$^\circ\text{C}$

- Notes:
1. Reverse Recovery Test Conditions: $I_F=0.5\text{A}$, $I_R=1.0\text{A}$, $I_{RR}=0.25\text{A}$
 2. Measured at 1 MHz and Applied $V_R=4.0$ Volts
 3. Thermal Resistance from Junction to Ambient and Junction to Lead Mounted on P.C.B. with 0.4" x 0.4" (10mm x 10 mm) Copper Pad Areas.

FIG. 1- MAXIMUM FORWARD CURRENT DERATING CURVE

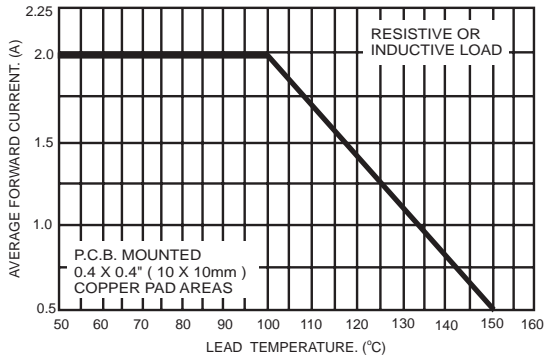

FIG. 2- TYPICAL REVERSE CHARACTERISTICS

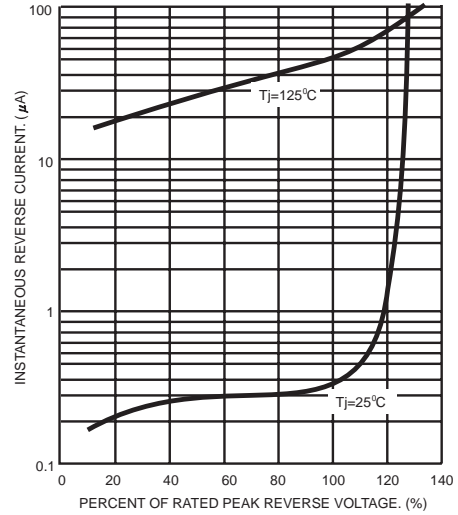

FIG. 3- MAXIMUM NON-REPETITIVE PEAK FORWARD SURGE CURRENT

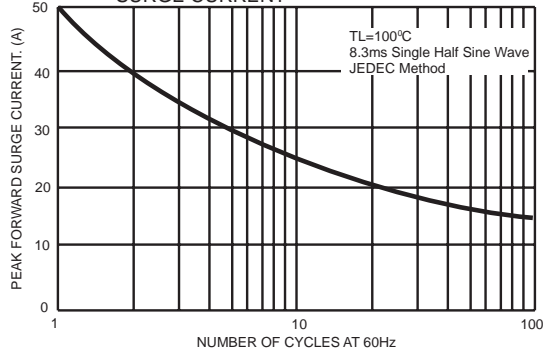

FIG. 5- TYPICAL INSTANTANEOUS FORWARD CHARACTERISTICS

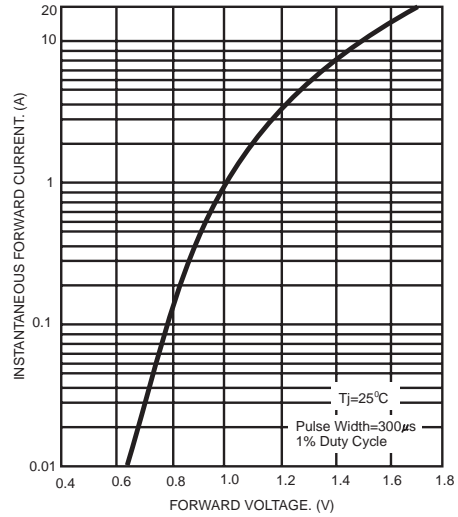

FIG. 4- TYPICAL JUNCTION CAPACITANCE

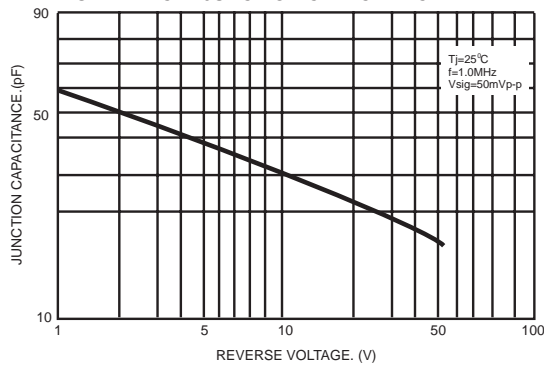

FIG. 6- REVERSE RECOVERY TIME CHARACTERISTIC AND TEST CIRCUIT DIAGRAM

